

## TABLE OF CONTENTS

CUSTOMER MESSAGE	Inside Front Cover
SAFETY PRECAUTIONS	3
GENERAL DESCRIPTION	6
SPECIFICATIONS	7
MAINTENANCE	9
OPERATION	10
REPAIRS AND REPLACEMENT	13
AIR DRIVE ASSEMBLY	15
TROUBLE SHOOTING	16
ACCESSORIES	18
ILLUSTRATED PARTS BREAKDOWN	19
DEWALT SAFETY INSTRUCTIONS	43
TOOL BIT RESHARPENING POLICY	Inside Back Cover
WARRANTY INFORMATION	Inside Back Cover

Copyright 2011  
Proprietary property of TRI TOOL Inc.  
No reproduction, use, or duplication of the information  
shown hereon is permitted without the express written  
consent of TRI TOOL Inc.

## SAFETY PRECAUTIONS

### IN GENERAL

When using rotating head cutting equipment, basic safety precautions should always be followed to reduce the risk of personal injury.

Operate this tool only in accordance with specific operating instructions.

#### **WARNING:**

Do not override the deadman switch on the power unit. Locking down, obstructing, or in any way defeating the deadman switch on the power drive unit may result in serious injury.

### DRESS CONSIDERATIONS

Use standard safety equipment. Hard hats, safety shoes, safety harnesses, protective clothes, and other safety devices should always be used when appropriate.

Use safety glasses. Do not operate cutting tools without eye protection.

Dress properly. Do not wear loose clothing or jewelry. They can be caught in rotating and moving parts. Avoid slippery floors or wear nonskid footwear. If you have long hair, wear protective hair covering to contain it.

### WORK AREA

Keep the work area clean. Cluttered work areas and benches invite injuries.

Consider the work area environment. Keep the area well lit. Keep electrical cords, cables, rags, rigging straps, and etc. clear of rotating equipment. Do not use power-cutting tools in the presence of flammable liquids and gasses.

Keep visitors away. Do not let visitors or untrained personnel at or near operating tools. Enforce eye protection requirements for all observers.

Do not over reach. Keep proper footing at all times.

Stay alert. Watch what you are doing. Use common sense. Do not operate tools when you are tired.

## **TOOL CARE**

Maintain tools with care. Keep tools in good operating condition. Sharp tool bits perform better and safer than dull tool bits. Well maintained tools function properly when needed.

Check for damaged parts. If a tool has malfunctioned, been dropped or hit, it must be checked for damage. Run no-load tests and feed function checks. Do a complete visual inspection.

Electric motors. Use only with proper AC voltage power sources and observe all normal electric shock hazard procedures.

Do not abuse power and control cords. Pulling or running over cords and cables can result in electrical shock hazards and malfunctions. Keep control and power cords out of all cutting fluids and water.

Hydraulic drives. Observe proper procedures for electrically driven power sources. Avoid damage to hydraulic lines. Keep quick-disconnects clean. Grit contamination causes malfunctions.

Air tools. Check the exhaust muffler. Broken or damaged mufflers can restrict air flow or cause excessive noise. Use air motors only with a filtered, lubricated and regulated air supply. Dirty air, low-pressure air or over pressure air will cause malfunctions, including delayed starting.

## **AREA EQUIPMENT**

Secure work. Whenever possible use clamps, vises, chains and straps to secure pipe.

Make sure the tool is secured; it is safer to have both hands free to operate the tool.

## **TOOL USE**

Use the right tool and tool bit for the job. Do not use a tool, which is incorrect for the job you are doing.

Keep the tool bits fully engaged in the tool bit holders. Loose bits are a safety hazard.

Disconnect power supply during setup and maintenance. Use all 'Stop' or Shut off' features available when changing or adjusting tool bits, maintaining the tool, or when the tool is not in use.

Remove adjusting keys and wrenches before applying power to the equipment. Develop a habit of checking the tool before turning it on to make sure that all keys and wrenches have been removed.

Do not force tools. Tools and tool bits function better and safer when used at the feed and speed rate for which they were designed.

Do not reach into rotating equipment. Do not reach into the rotating head stock to clear chips, to make adjustments, or to check surface finish. A machine designed to cut steel will not stop for a hand or an arm.

Handle chips with care. Chips have very sharp edges and are hot. Do not try to pull chips apart with are hands; they are very tough.

Avoid unintentional starts. Do not carry or handle tools with your hand on the operating switches or levers. Do not lay the tool down in a manner that will start the drive. Do not allow the tool to flip around or move when adjusting or changing tool bits.

Store idle tools properly. Disconnect tools from the power source and store in a safe place. Remove tool bits for safe handling of the tool.

## **GENERAL DESCRIPTION**

The Model 550 Tube Severing Tool series of tube cutters is designed to cut tubing in areas where access to and around the tube is limited.

The Model 550 uses a cutter wheel to sever the tube. Normal operation will not produce chips.

The Model 550 is powered by Tri Tool Inc. pneumatic, electrical or manual Drive Units.

The Model 550 features an automatic feed, which permits an even pressure on the cutting wheel during operation.

**SPECIFICATIONS**

Envelope, Model 550-00, Tube Severing Tool

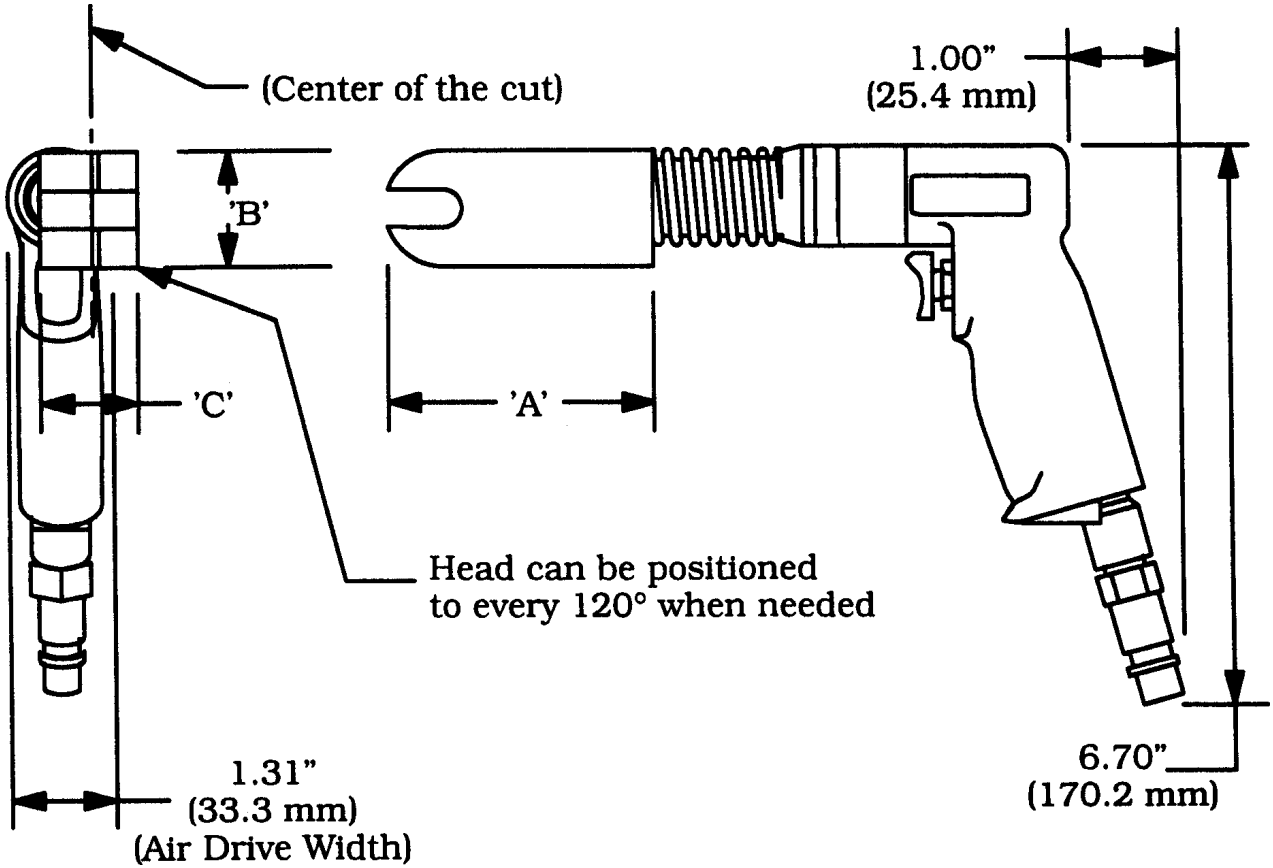

<b>Envelope, Model 550-00, Tube Severing Tool</b>						
<b>Model No.</b>	<b>P/N</b>	<b>Tube Size</b>	<b>"A"</b>	<b>"B"</b>	<b>"C"</b>	<b>Weight</b>
550-03	01-1062	3/16" (4.8 mm)	3.67" (93.2 mm)	1.50" (38.8 mm)	1.25" (31.8 mm)	.75 lb (.34 kg)
550-04	01-1063	1/4" (6.4 mm)	3.67" (93.2 mm)	1.50" (38.8 mm)	1.25" (31.8 mm)	.75 lb (.34 kg)
550-05	01-1064	5/16" (7.9 mm)	3.67" (93.2 mm)	1.50" (38.8 mm)	1.25" (31.8 mm)	.75 lb (.34 kg)
550-06	01-1009	3/8" (9.5 mm)	3.67" (93.2 mm)	1.50" (38.8 mm)	1.25" (31.8 mm)	.75 lb (.34 kg)
550-08	01-1065	1/2" (12.7 mm)	4.36" (110.7 mm)	2.25" (57.2 mm)	1.53" (38.9 mm)	2.25 lb (1.02 kg)
550-10	01-1066	5/8" (15.9 mm)	4.53" (115.1 mm)	2.38" (60.5 mm)	1.53" (38.9 mm)	2.47 lb (1.12 kg)
550-12	01-1067	3/4" (19.1 mm)	4.63" (117.6 mm)	2.50" (63.5 mm)	1.53" (38.9 mm)	2.65 lb (1.20 kg)
550-14	01-1075	7/8" (22.2 mm)	4.88" (124.0 mm)	2.63" (66.8 mm)	1.53" (38.9 mm)	2.94 lb (1.33 kg)
550-16	01-1068	1" (25.4 mm)	5.02" (127.5 mm)	2.75" (69.9 mm)	1.53" (38.9 mm)	3.16 lb (1.43 kg)
550-18	01-1069	1 1/8" (28.6 mm)	5.88" (149.4 mm)	3.13" (79.5 mm)	1.53" (38.9 mm)	4.22 lb (1.91 kg)
550-20	01-1070	1 1/4" (31.8 mm)	6.13" (155.6 mm)	3.38" (85.9 mm)	1.56" (39.6 mm)	4.85 lb (2.20 kg)
550-24	01-1071	1 1/2" (38.1 mm)	7.10" (180.3 mm)	4.00" (101.6 mm)	1.56" (39.6 mm)	6.64 lb (3.01 kg)
550-28	01-1072	1 3/4" (44.5 mm)	7.70" (195.6 mm)	4.38" (111.3 mm)	1.56" (39.6 mm)	7.87 lb (3.57 kg)
550-32	01-1073	2" (50.8 mm)	8.19" (208.0 mm)	4.75" (120.7 mm)	1.56" (39.6 mm)	9.10 lb (4.13 kg)



## **MAINTENANCE**

All components should be periodically cleaned and coated with a light film of oil.

Use a clean, non-detergent oil, preferably SAE 10 (90 SSU or lighter.)

The Cutting Wheel should be replaced if worn or damaged.

The Cutting Wheel life depends upon the tube material, wall thickness, and operator's experience.

Short and long bearing plugs should be replaced when worn, damaged or scratches occur on the tube being cut.

# OPERATION

Read the operating instructions carefully before attempting to operate the Model 550 Tube Severing Tool.

Be sure to use eye protection at all times when operating the Model 550.

Select the proper Model 550 for the size of tubing to be severed.

Maximum Tube Wall Thickness				
Model No.	Tube Size	Aluminum	Stainless Steel	Titanium
550-03	3/16" (4.8 mm)	.065" (1.6 mm)	.065" (1.6 mm)	.065" (1.6 mm)
550-04	1/4" (6.4 mm)			
550-05	5/16" (7.9 mm)			
550-06	3/8" (9.5 mm)			
550-08	1/2" (12.7 mm)	.095" (2.4 mm)	.100" (2.5 mm)	.100" (2.5 mm)
550-10	5/8" (15.9 mm)	.125" (3.2 mm)		
550-12	3/4" (19.1 mm)	.095" (2.4 mm)		
550-14	7/8" (22.2 mm)	.125" (3.2 mm)		
550-16	1" (25.4 mm)	.095" (2.4 mm)		
550-18	1 1/8" (28.6 mm)	.125" (3.2 mm)		
550-20	1 1/4" (31.8 mm)	.100" (2.5 mm)		
550-24	1 1/2" (38.1 mm)	.110" (2.8 mm)		
550-28	1 3/4" (44.5 mm)	.125" (3.2 mm)		
550-32	2" (50.8 mm)			

Be sure the Cutter Wheel of the Tube Severing Tool you have selected is sharp, rotates freely and is not damaged in any way.

A damaged or non-rotating Cutter Wheel can affect the performance of the tool.

Be sure Bearing Plugs are clean and not damaged.

Damaged Bearing Plugs affect the performance of the tool and should be changed.

Select the proper Tri Tool Inc. Drive Unit that best suits the operation needed to be performed.

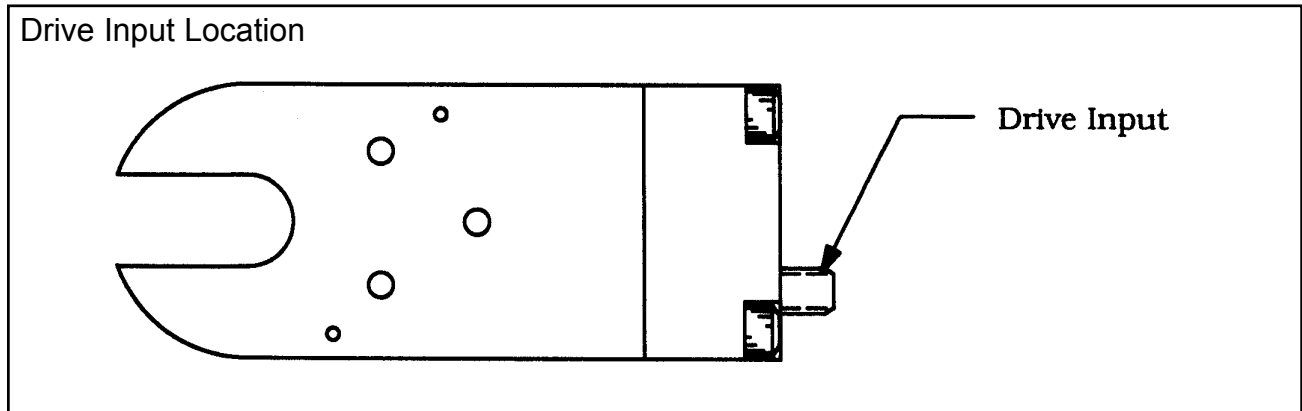

A non Tri Tool Inc. Drive Unit will void the warranty.

**NOTE:** If input is counterclockwise, sever damage will occur during cutting.

### CONNECTING AND DISCONNECTING THE DRIVE SYSTEM TO THE MODEL 550

The entire series of Model 550 Tube Cutters are equipped with a quick disconnect drive-mounting system.

The drive units, which are equipped with a mating quick disconnect, are universal, they will operate with any Model 550 size that is selected.

### **! WARNING !**

Disconnect the Drive Unit from its power source when installing or removing it from the Model 550 Tub Cutter otherwise serious injury may occur.

To connect an air or electric drive unit, simply align the slots of the drive system to the pin located inside the Model 550 coupling, push the drive system inward and rotate counterclockwise and release.

The drive unit is equipped with a spring to allow it to lock securely.

The drive unit should now be locked in place.

Align the slot.

The rotation direction of the input must be clockwise.

Rotate drive shaft in a clockwise direction to align the slot.

If you miss alignment, simply realign the slot.

Load the Model 550 around the tube to be cut.

Apply a light force to insure that the Model 550 is over the tube.

The Model 550 must be held perpendicular to the surface of the tube to be cut.

Turn on the power for the Model 550 and begin the tube sever.

After the tube has severed, continue rotation, observing the cutting wheels until they have returned to the home position.

Turn the power off.

Remove the Model 550 from the tube.

## REPAIRS AND REPLACEMENT

**WARNING:** Disconnect the Drive Unit from the Model 550 Tube Cutter prior to any repairs or replacements.

Rotate the drive shaft manually clockwise to rotate the cutter carriage to the desired position.

### REPLACEMENT OF THE CUTTER WHEEL

Rotate the Cutter Carriage Assy until you see the Cutting Wheel and the cutter Wheel Securing Pin access hole.

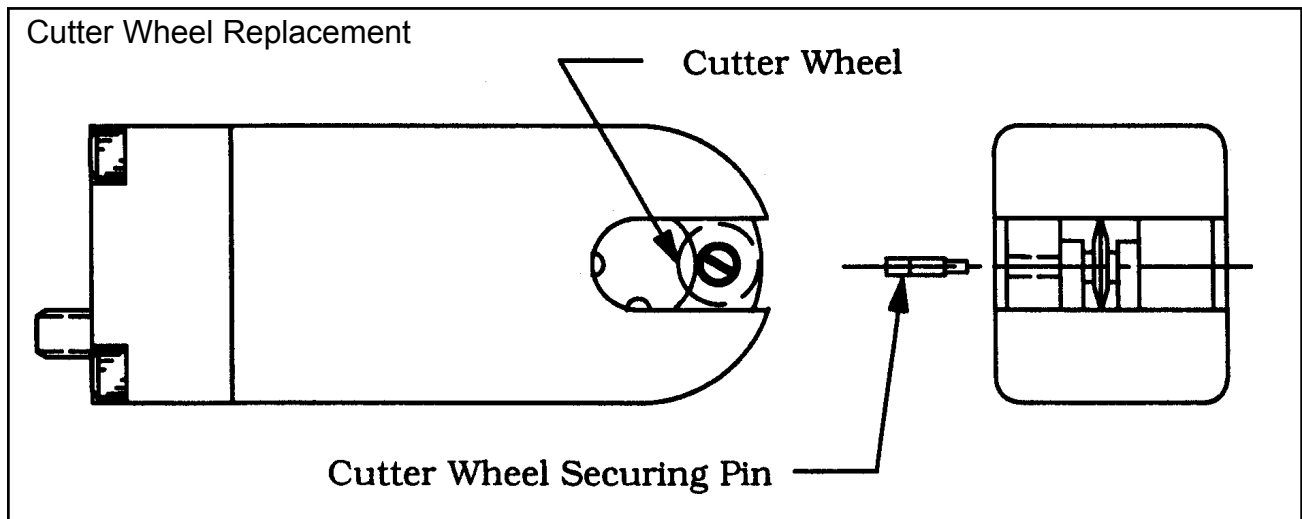

Take a small screwdriver and a pair of needle nose pliers to remove the Wheel Securing Pin.

Insert a pair of needle nose pliers and take hold of the edge of the Cutter Wheel and remove it from the Model 550 Tube Cutter.

Take the new Cutter Wheel and install it by reversing the removal procedure.

### REPLACEMENT OF THE BEARING PLUGS

Rotate the Cutter Carriage Assy until the Bearing Plug that is to be replaced can be seen.

Press out the worn Bearing Plug.

Press in the new Bearing Plug.

Refer to the Illustrated Parts Breakdown for the correct Bearing Plug.

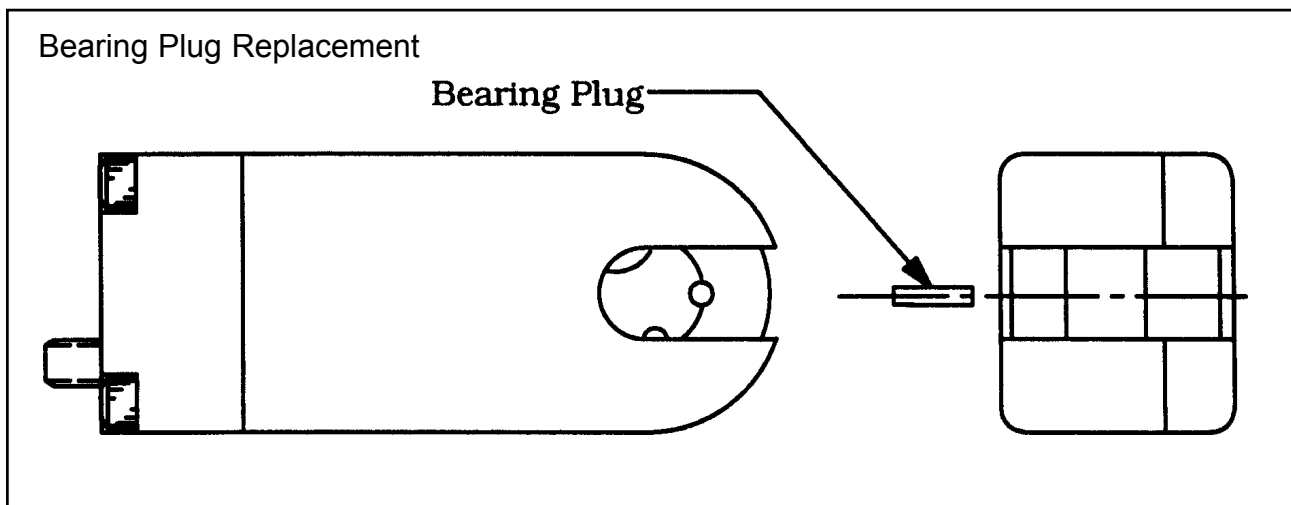

## AIR DRIVE ASSEMBLY

### REMOVAL OF A SHEARED ROLL PIN FROM THE DRIVE ASSY.

Push the Air Drive Assy into the Model 550 Tube Cutter and rotate it clockwise and pull it out.

Unscrew the Bayonet Mounting Tube from the Motor Housing by rotating the Bayonet Mounting Tube counterclockwise.

Take a punch and gently remove the remaining parts of the Roll Pin from the Drive Shaft and the Motor Shaft.

### ASSEMBLY OF THE DRIVE ASSY.

Press Roll Pin partly into one side of hole in Drive Shaft being careful not to protrude into inside diameter.

Position Drive Shaft onto the Motor Shaft and press Roll Pin into the Shafts.

Recess the Roll Pin slightly below the surface of the outside diameter of the Drive Shaft using a punch.

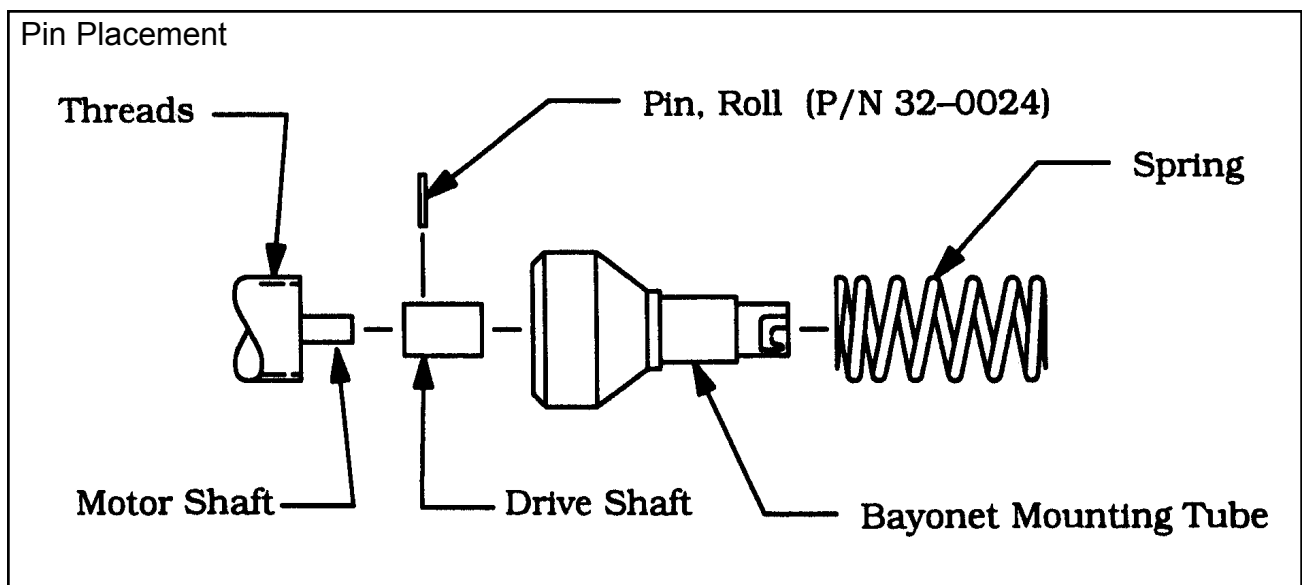

Slide the Bayonet Mounting Tube over the Drive Shaft and screw the Bayonet Mounting Tube onto the Motor Housing by rotating clockwise.

## TROUBLE SHOOTING

### **Problem: The Tool Bit Chatters**

**Probable causes:**

- The tool bit is loose or overextended.
- The tool bit is damaged.
- The tool holder is too loose in the slides.
- The cutting speed is too fast.
- The clamping pads are loose on the pipe or tube.
- Cutting fluid is required.
- The main bearing pre-load is loose.

### **Problem: There is excessive Tool Bit wear**

**Probable causes:**

- The pipe or tube material is too hard or abrasive.
- The cutting speed is too fast.
- Cutting fluid is required.
- A dull Tool Bit is causing surface hardening conditions (Stainless pipe or tubing).
- There is scale or other foreign matter on the pipe or tube, which is dulling the tool bit at the start of the cut.
- The tool bit is incorrect for the material being cut.

### **Problem: The surface finish is rough**

**Probable causes:**

- The tool bit is dull, chipped, etc.
- Metal build-up on the cutting edge of the tool bit is creating a false cutting edge.
- Cutting fluid is required.



**Problem: The tool holder is not feeding**

**Probable causes:**

- The feed pin is broken or out of position.
- The feed sprocket shear pin is broken.
- The feed screw is stripped.
- The feed nut is stripped.
- The slide rails are too tight.

**Problem: There is a loss of air power**

**Probable causes:**

- The air supply pressure is too low.
- The air filter is plugged.
- The air line size is insufficient.
- The air line is too long.

**Problem: There is a loss of hydraulic power**

**Probable causes:**

- The hydraulic supply pressure is too low.
- The hydraulic filter is plugged.
- The hydraulic line size is insufficient.
- The hydraulic line is too long.

**Problem: The tool bit will not reach the work**

**Probable causes:**

- Incorrect tool blocks are installed for the size of the pipe or tube being worked on.
- Incorrect tool bit is installed.

**Problem: The hydraulic motor will not start**

**Probable causes:**

- The hydraulic power supply is shut off.
- The hydraulic motor is damaged and will not run free.

## **ACCESSORIES**

The following accessories are recommended for use with the Model 550 Tube Cutters and are available from TRI TOOL INC.

1. Portable Air Filter (P/N 75-0115)
2. Drive Assembly, Air (P/N 04-0084)
3. Shaft Assembly, 18" Flexible (P/N 14-0036)
4. Motor Assembly, Cordless, 14.4V (P/N 58-0213)

A Filter/Regulator/Lubricator (FRL) is required to protect the warranty on all TRI TOOL INC air driven tools.

**ILLUSTRATED PARTS BREAKDOWN**

**MODEL 550-03, 04, 05, AND 06  
TUBE SEVERING TOOL ASSEMBLY (P/N 01-XXXX)**

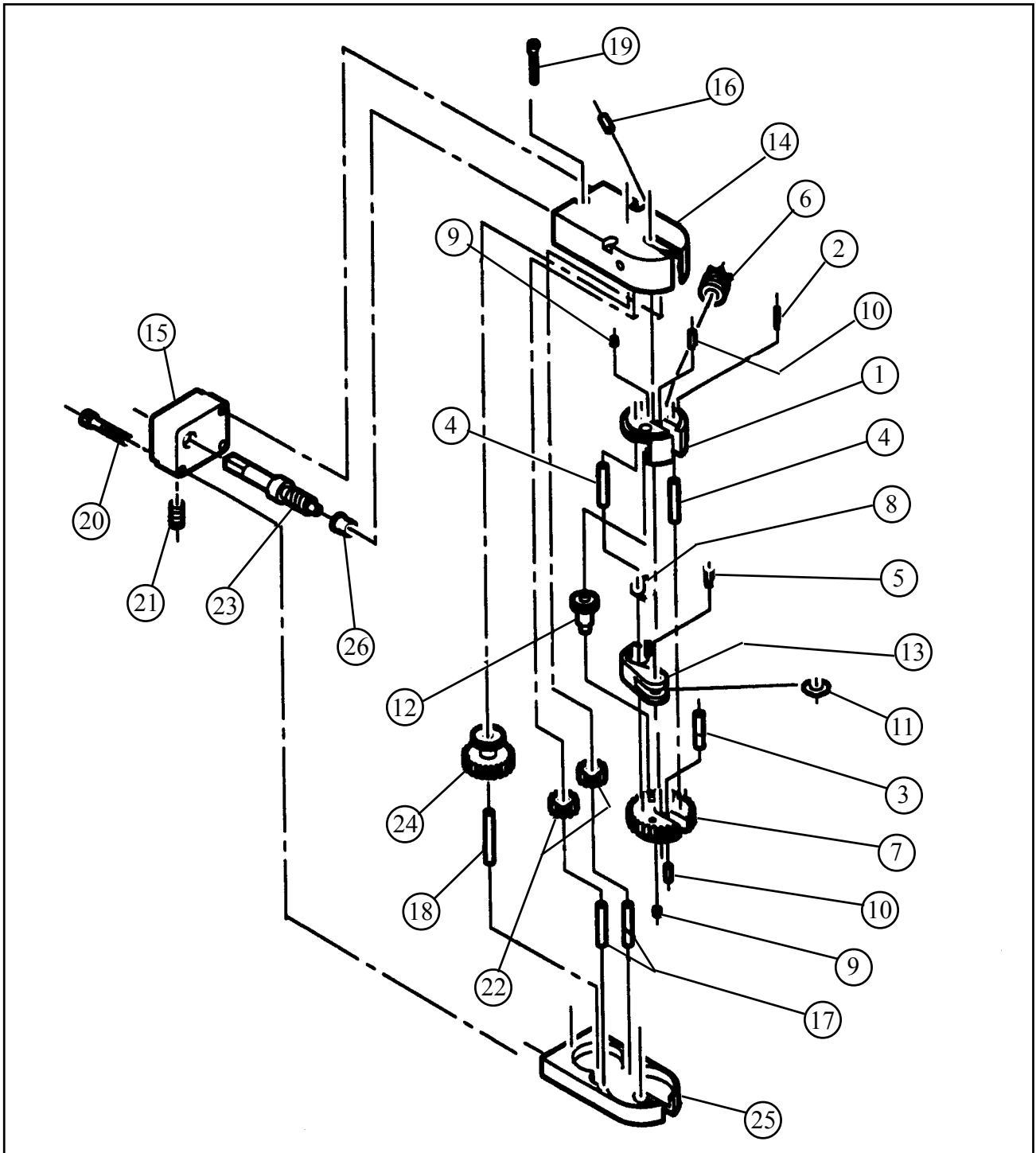

**TRI TOOL INC.**

---

## Parts List, Model 550-03, Tube Cutter (P/N 01-1062)

<b>Item No.</b>	<b>Part No.</b>	<b>Description</b>	<b>Qty</b>
	02-2057	CARRIAGE ASSEMBLY, CUTTER	1
1.	19-0353	HOUSING, CARRIAGE, TUBE CUTTER	1
2.	32-0003	PIN, ROLL, 1/16" DIA X 1/2"	1
3.	32-0179	PIN, DOWEL, 3/16" DIA X 5/8"	1
4.	32-0226	PIN, DOWEL, 3/16" DIA X 1" LONG	2
5.	32-0251	PIN, CUTTER	1
6.	38-0065	SPROCKET ASSEMBLY, FEED	1
7.	39-0382	GEAR, CARRIAGE, 12DP, 29T, 1.21PD	1
8.	40-0139	SPRING, TORSION	1
9.	54-0270	PLUG, SHORT, BEARING	2
10.	54-0271	PLUG, LONG, BEARING	2
11.	61-0017	WHEEL, CUTTER, 1/2"	1
12.	62-0066	CAM ASSEMBLY, AUTOFEED	1
13.	63-0081	ARM, CUTTER	1
14.	19-0355	HOUSING, MAIN	1
15.	24-0518	PLATE, RETAINING	1
16.	32-0172	PIN, TRIPPER, 3/32"	2
17.	32-0179	PIN, DOWEL, 3/16" DIA X 5/8"	2
18.	32-0272	PIN, DOWEL, 3/16" X 1 1/4"	1
19.	33-0017	SCREW, CAP, #6-32 X 1"	3
20.	33-0024	SCREW, CAP, #8-32 X 1"	3
21.	33-0927	SCREW, SET, 1/4-20 X 1/2", HDOG	1
22.	39-0289	GEAR, PINION	2
23.	39-0295	GEAR ASSEMBLY, WORM	1
24.	39-0335	GEAR, DRIVE, 24DP, 30T, .96PD	1
25.	43-0274	COVER, MAIN HOUSING	1
26.	45-0112	BUSHING, BRONZE, FL, 3/16" X 5/16" X 1/4"	1

## Model 550 Tube Severing Tool

### Parts List, Model 550-04, Tube Cutter (P/N 01-1063)

Item No.	Part No.	Description	Qty
	02-2058	CARRIAGE ASSEMBLY, CUTTER	1
1.	19-0354	HOUSING, CARRIAGE, TUBE CUTTER	1
2.	32-0003	PIN, ROLL, 1/16" DIA X 1/2"	1
3.	32-0179	PIN, DOWEL, 3/16" DIA X 5/8"	1
4.	32-0226	PIN, DOWEL, 3/16" DIA X 1" LONG	2
5.	32-0251	PIN, CUTTER	1
6.	38-0065	SPROCKET ASSEMBLY, FEED	1
7.	39-0381	GEAR, CARRIAGE, 12DP, 29T, 1.21PD	1
8.	40-0139	SPRING, TORSION	1
9.	54-0270	PLUG, SHORT, BEARING	2
10.	54-0271	PLUG, LONG, BEARING	2
11.	61-0017	WHEEL, CUTTER, 1/2	1
12.	62-0066	CAM ASSEMBLY, AUTOFEED	1
13.	63-0081	ARM, CUTTER	1
14.	19-0438	HOUSING, MAIN	1
15.	24-0518	PLATE, RETAINING	1
16.	32-0172	PIN, TRIPPER, 3/32"	2
17.	32-0179	PIN, DOWEL, 3/16" DIA X 5/8"	2
18.	32-0272	PIN, DOWEL, 3/16" X 1 1/4"	1
19.	33-0017	SCREW, CAP, #6-32 X 1"	3
20.	33-0024	SCREW, CAP, #8-32 X 1"	3
21.	33-0927	SCREW, SET, 1/4-20 X 1/2", HDOG	1
22.	39-0289	GEAR, PINION	2
23.	39-0295	GEAR ASSEMBLY, WORM	1
24.	39-0335	GEAR, DRIVE, 24DP, 30T, .96PD	1
25.	43-0274	COVER, MAIN HOUSING	1
26.	45-0112	BUSHING, BRONZE, FL, 3/16" X 5/16" X 1/4"	1

**TRI TOOL INC.**

---

## Parts List, Model 550-05, Tube Cutter (P/N 01-1064)

<b>Item No.</b>	<b>Part No.</b>	<b>Description</b>	<b>Qty</b>
	02-2059	CARRIAGE ASSEMBLY, CUTTER	1
1.	19-0356	HOUSING, CARRIAGE, TUBE CUTTER	1
2.	32-0003	PIN, ROLL, 1/16" DIA X 1/2"	1
3.	32-0179	PIN, DOWEL, 3/16" DIA X 5/8"	1
4.	32-0226	PIN, DOWEL, 3/16" DIA X 1" LONG	2
5.	32-0251	PIN, CUTTER	1
6.	38-0065	SPROCKET ASSEMBLY, FEED	1
7.	39-0380	GEAR, CARRIAGE, 12DP, 29T, 1.21PD	1
8.	40-0139	SPRING, TORSION	1
9.	54-0270	PLUG, SHORT, BEARING	2
10.	54-0271	PLUG, LONG, BEARING	2
11.	61-0017	WHEEL, CUTTER, 1/2"	1
12.	62-0066	CAM ASSEMBLY, AUTOFEED	1
13.	63-0081	ARM, CUTTER	1
14.	19-0439	HOUSING, MAIN	1
15.	24-0518	PLATE, RETAINING	1
16.	32-0172	PIN, TRIPPER, 3/32"	2
17.	32-0179	PIN, DOWEL, 3/16" DIA X 5/8"	2
18.	32-0272	PIN, DOWEL, 3/16" X 1 1/4"	1
19.	33-0017	SCREW, CAP, #6-32 X 1"	3
20.	33-0024	SCREW, CAP, #8-32 X 1"	3
21.	33-0927	SCREW, SET, 1/4-20 X 1/2", HDOG	1
22.	39-0289	GEAR, PINION	2
23.	39-0295	GEAR ASSEMBLY, WORM	1
24.	39-0335	GEAR, DRIVE, 24DP, 30T, .96PD	1
25.	43-0271	COVER, MAIN HOUSING	1
26.	45-0112	BUSHING, BRONZE, FL, 3/16" X 5/16" X 1/4"	1

## Model 550 Tube Severing Tool

### Parts List, Model 550-06, Tube Cutter (P/N 01-1009)

Item No.	Part No.	Description	Qty
	02-2060	CARRIAGE ASSEMBLY, CUTTER	1
1.	19-0352	HOUSING, CARRIAGE, TUBE CUTTER	1
2.	32-0003	PIN, ROLL, 1/16" DIA X 1/2"	1
3.	32-0179	PIN, DOWEL, 3/16" DIA X 5/8"	1
4.	32-0226	PIN, DOWEL, 3/16" DIA X 1" LONG	2
5.	32-0251	PIN, CUTTER	1
6.	38-0065	SPROCKET ASSEMBLY, FEED	1
7.	39-0378	GEAR, CARRIAGE, 12DP, 29T, 1.21PD	1
8.	40-0139	SPRING, TORSION	1
9.	54-0270	PLUG, SHORT, BEARING	2
10.	54-0271	PLUG, LONG, BEARING	2
11.	61-0017	WHEEL, CUTTER, 1/2"	1
12.	62-0066	CAM ASSEMBLY, AUTOFEED	1
13.	63-0081	ARM, CUTTER	1
14.	19-0351	HOUSING, MAIN	1
15.	24-0518	PLATE, RETAINING	1
16.	32-0172	PIN, TRIPPER, 3/32"	2
17.	32-0179	PIN, DOWEL, 3/16" DIA X 5/8"	2
18.	32-0272	PIN, DOWEL, 3/16" X 1 1/4"	1
19.	33-0017	SCREW, CAP, #6-32 X 1"	3
20.	33-0024	SCREW, CAP, #8-32 X 1"	3
21.	33-0927	SCREW, SET, 1/4-20 X 1/2", HDOG	1
22.	39-0289	GEAR, PINION	2
23.	39-0295	GEAR ASSEMBLY, WORM	1
24.	39-0335	GEAR, DRIVE, 24DP, 30T, .96PD	1
25.	43-0271	COVER, MAIN HOUSING	1
26.	45-0112	BUSHING, BRONZE, FL, 3/16" X 5/16" X 1/4"	1

MODEL 550-08 TUBE SEVERING TOOL ASSEMBLY (P/N 01-1065)

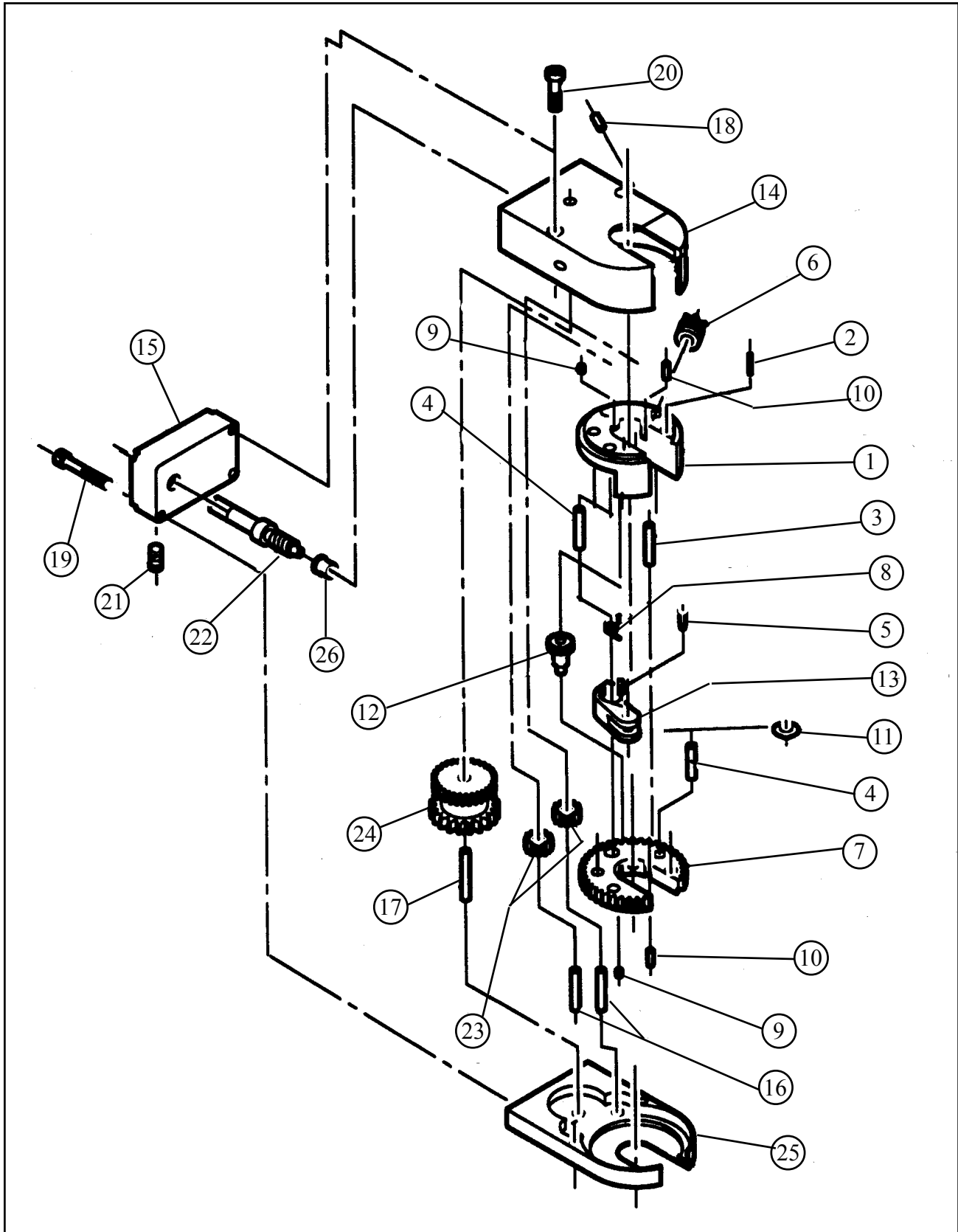



## Model 550 Tube Severing Tool

### Parts List, Model 550-08, Tube Cutter (P/N 01-1065)

Item No.	Part No.	Description	Qty
	02-2061	CARRIAGE ASSEMBLY, CUTTER	1
1.	19-0348	HOUSING, TUBE CUTTER	1
2.	32-0019	PIN, ROLL, 3/32" DIA X 7/8"	1
3.	32-0114	PIN, DOWEL, 1/4" DIA X 1 1/4"	2
4.	32-0140	PIN, DOWEL, 1/4" DIA X 3/4"	1
5.	32-0248	PIN, WHEEL SECURING	1
6.	38-0067	SPROCKET ASSEMBLY, FEED	1
7.	39-0374	GEAR, CARRIAGE	1
8.	40-0141	SPRING, TORSION	1
9.	54-0270	PLUG, SHORT, BEARING	2
10.	54-0271	PLUG, LONG, BEARING	2
11.	61-0009	WHEEL, CUTTER, 3/4"	1
12.	62-0069	CAM ASSEMBLY, FEED	1
13.	63-0085	ARM, CUTTER	1
14.	19-0306	HOUSING, MAIN	1
15.	24-0527	PLATE, RETAINING	1
16.	32-0206	PIN, DOWEL, 1/4" DIA X 5/8"	2
17.	32-0170	PIN, DOWEL, 1/4" DIA X 1 1/2"	1
18.	32-0188	PIN, TRIPPER, 1/8"	2
19.	33-0024	SCREW, CAP, #8-32 X 1"	4
20.	33-0025	SCREW, CAP, #8-32 X 1 1/4"	2
21.	33-0927	SCREW, SET, 1/4-20 X 1/2", HDOG	1
22.	39-0273	GEAR, ASSEMBLY, WORM	1
23.	39-0307	GEAR, PINION	2
24.	39-0388	GEAR, DRIVE	1
25.	43-0248	COVER, HOUSING	1
26.	45-0098	BUSHING, BRONZE	1

MODEL 550-10, 12, 14 AND 16  
TUBE SEVERING TOOL ASSEMBLY (P/N 01-10XX)

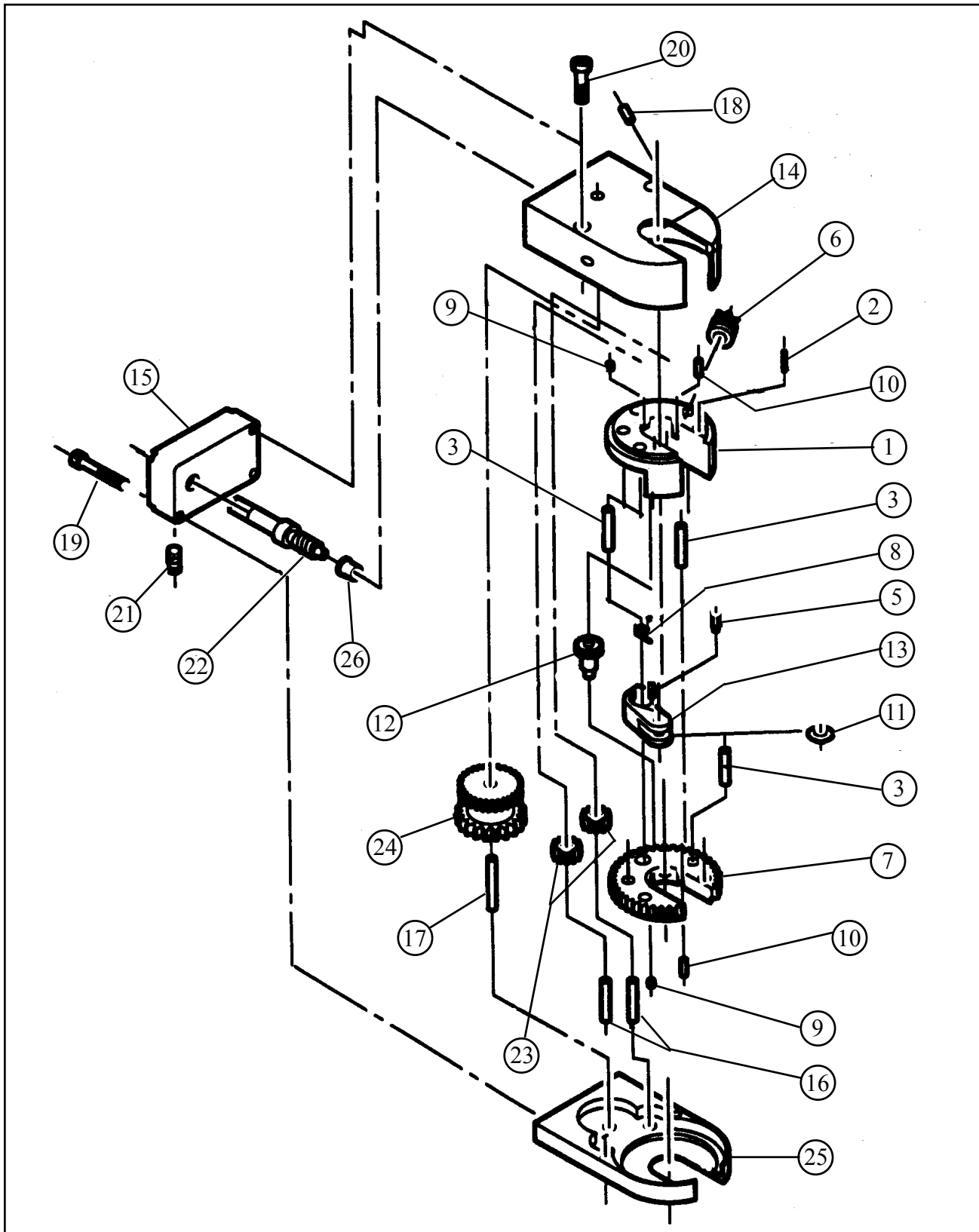

## Model 550 Tube Severing Tool

### Parts List, Model 550-10, Tube Cutter (P/N 01-1066)

Item No.	Part No.	Description	Qty
	02-2062	CARRIAGE ASSEMBLY, CUTTER	1
1.	19-0347	HOUSING, CUTTER	1
2.	32-0019	PIN, ROLL, 3/32" DIA X 7/8"	1
3.	32-0114	PIN, DOWEL, 1/4" DIA X 1 1/4"	2
4.			
5.	32-0248	PIN, WHEEL SECURING	1
6.	38-0067	SPROCKET ASSEMBLY, FEED	1
7.	39-0372	GEAR, CARRIAGE	1
8.	40-0141	SPRING, TORSION	1
9.	54-0272	PLUG, SHORT, BEARING	2
10.	54-0273	PLUG, LONG, BEARING	2
11.	61-0009	WHEEL, CUTTER, 3/4"	1
12.	62-0070	CAM ASSEMBLY, FEED	1
13.	63-0085	ARM, CUTTER	1
14.	19-0307	HOUSING, MAIN	1
15.	24-0528	PLATE, RETAINING	1
16.	32-0206	PIN, DOWEL, 1/4" DIA X 5/8"	2
17.	32-0170	PIN, DOWEL, 1/4" DIA X 1 1/2"	1
18.	32-0188	PIN, TRIPPER, 1/8"	2
19.	33-0032	SCREW, CAP, #10-24 X 1"	4
20.	33-0033	SCREW, CAP, #10-24 X 1 1/4"	2
21.	33-0927	SCREW, SET, 1/4-20 X 1/2", HDOG	1
22.	39-0273	GEAR, ASSEMBLY, WORM	1
23.	39-0307	GEAR, PINION	2
24.	39-0388	GEAR, DRIVE	1
25.	43-0250	COVER, HOUSING	1
26.	45-0098	BUSHING, BRONZE	1

**TRI TOOL INC.**

---

## Parts List, Model 550-12, Tube Cutter (P/N 01-1067)

<b>Item No.</b>	<b>Part No.</b>	<b>Description</b>	<b>Qty</b>
	02-2063	CARRIAGE ASSEMBLY, CUTTER	1
1.	19-0346	HOUSING, CUTTER	1
2.	32-0019	PIN, ROLL, 3/32" DIA X 7/8"	1
3.	32-0114	PIN, DOWEL, 1/4" DIA X 1 1/4"	2
4.			
5.	32-0248	PIN, WHEEL SECURING	1
6.	38-0067	SPROCKET ASSEMBLY, FEED	1
7.	39-0371	GEAR, CARRIAGE	1
8.	40-0141	SPRING, TORSION	1
9.	54-0272	PLUG, SHORT, BEARING	2
10.	54-0273	PLUG, LONG, BEARING	2
11.	61-0009	WHEEL, CUTTER, 3/4"	1
12.	62-0079	CAM ASSEMBLY, FEED	1
13.	63-0086	ARM, CUTTER	1
14.	19-0308	HOUSING, MAIN	1
15.	24-0529	PLATE, RETAINING	1
16.	32-0206	PIN, DOWEL, 1/4" DIA X 5/8"	2
17.	32-0170	PIN, DOWEL, 1/4" DIA X 1 1/2"	1
18.	32-0188	PIN, TRIPPER, 1/8"	2
19.	33-0032	SCREW, CAP, #10-24 X 1"	4
20.	33-0033	SCREW, CAP, #10-24 X 1 1/4"	2
21.	33-0927	SCREW, SET, 1/4-20 X 1/2", HDOG	1
22.	39-0273	GEAR, ASSEMBLY, WORM	1
23.	39-0307	GEAR, PINION	2
24.	39-0388	GEAR, DRIVE	1
25.	43-0249	COVER, HOUSING	1
26.	45-0098	BUSHING, BRONZE	1

## Model 550 Tube Severing Tool

### Parts List, Model 550-14, Tube Cutter (P/N 01-1075)

Item No.	Part No.	Description	Qty
	02-2064	CARRIAGE ASSEMBLY, CUTTER	1
1.	19-0357	HOUSING, CUTTER	1
2.	32-0019	PIN, ROLL, 3/32" DIA X 7/8"	1
3.	32-0114	PIN, DOWEL, 1/4" DIA X 1 1/4"	2
4.			
5.	32-0248	PIN, WHEEL SECURING	1
6.	38-0067	SPROCKET ASSEMBLY, FEED	1
7.	39-0390	GEAR, CARRIAGE	1
8.	40-0141	SPRING, TORSION	1
9.	54-0272	PLUG, SHORT, BEARING	2
10.	54-0273	PLUG, LONG, BEARING	2
11.	61-0009	WHEEL, CUTTER, 3/4"	1
12.	62-0079	CAM ASSEMBLY, FEED	1
13.	63-0086	ARM, CUTTER	1
14.	19-0341	HOUSING, MAIN	1
15.	24-0574	PLATE, RETAINING	1
16.	32-0206	PIN, DOWEL, 1/4" DIA X 5/8"	2
17.	32-0170	PIN, DOWEL, 1/4" DIA X 1 1/2"	1
18.	32-0188	PIN, TRIPPER, 1/8"	2
19.	33-0032	SCREW, CAP, #10-24 X 1"	4
20.	33-0033	SCREW, CAP, #10-24 X 1 1/4"	2
21.	33-0927	SCREW, SET, 1/4-20 X 1/2", HDOG	1
22.	39-0273	GEAR, ASSEMBLY, WORM	1
23.	39-0306	GEAR, PINION	2
24.	39-0389	GEAR, DRIVE	1
25.	43-0268	COVER, HOUSING	1
26.	45-0098	BUSHING, BRONZE	1

**TRI TOOL INC.**

---

## Parts List, Model 550-16, Tube Cutter (P/N 01-1068)

<b>Item No.</b>	<b>Part No.</b>	<b>Description</b>	<b>Qty</b>
	02-2065	CARRIAGE ASSEMBLY, CUTTER	1
1.	19-0366	HOUSING, CUTTER	1
2.	32-0019	PIN, ROLL, 3/32" DIA X 7/8"	1
3.	32-0114	PIN, DOWEL, 1/4" DIA X 1 1/4"	2
4.			
5.	32-0248	PIN, WHEEL SECURING	1
6.	38-0067	SPROCKET ASSEMBLY, FEED	1
7.	39-0416	GEAR, CARRIAGE	1
8.	40-0141	SPRING, TORSION	1
9.	54-0272	PLUG, SHORT, BEARING	2
10.	54-0273	PLUG, LONG, BEARING	2
11.	61-0009	WHEEL, CUTTER, 3/4"	1
12.	62-0058	CAM ASSEMBLY, FEED	1
13.	63-0084	ARM, CUTTER	1
14.	19-0305	HOUSING, MAIN	1
15.	24-0525	PLATE, RETAINING	1
16.	32-0206	PIN, DOWEL, 1/4" DIA X 5/8"	2
17.	32-0170	PIN, DOWEL, 1/4" DIA X 1 1/2"	1
18.	32-0188	PIN, TRIPPER, 1/8"	2
19.	33-0032	SCREW, CAP, #10-24 X 1"	4
20.	33-0033	SCREW, CAP, #10-24 X 1 1/4"	2
21.	33-0927	SCREW, SET, 1/4-20 X 1/2", HDOG	1
22.	39-0273	GEAR, ASSEMBLY, WORM	1
23.	39-0306	GEAR, PINION	2
24.	39-0362	GEAR, DRIVE	1
25.	43-0247	COVER, HOUSING	1
26.	45-0098	BUSHING, BRONZE	1

MODEL 550-18, 20, 24 AND 28 TUBE SEVERING TOOL ASSEMBLY

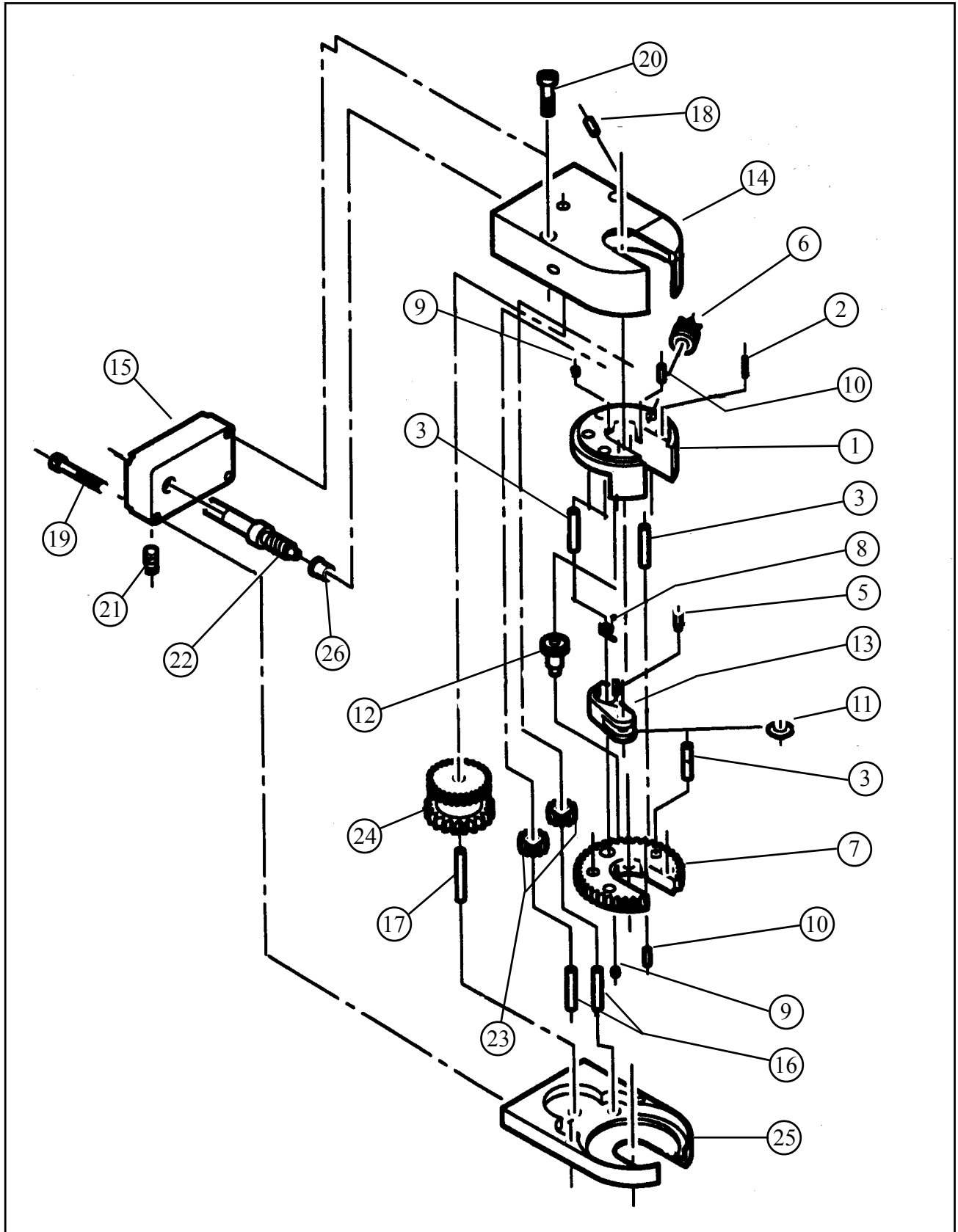

**TRI TOOL INC.**

---

## Parts List, Model 550-18, Tube Cutter (P/N 01-1069)

<b>Item No.</b>	<b>Part No.</b>	<b>Description</b>	<b>Qty</b>
	02-2066	CARRIAGE ASSEMBLY, CUTTER	1
1.	19-0359	HOUSING, CUTTER	1
2.	32-0019	PIN, ROLL, 3/32" DIA X 7/8"	1
3.	32-0114	PIN, DOWEL, 1/4" DIA X 1 1/4"	2
4.			
5.	32-0248	PIN, WHEEL SECURING	1
6.	38-0068	SPROCKET ASSEMBLY, FEED	1
7.	39-0387	GEAR, CARRIAGE	1
8.	40-0141	SPRING, TORSION	1
9.	54-0272	PLUG, SHORT, BEARING	2
10.	54-0273	PLUG, LONG, BEARING	2
11.	61-0009	WHEEL, CUTTER, 3/4"	1
12.	62-0075	CAM ASSEMBLY, FEED	1
13.	63-0084	ARM, CUTTER	1
14.	19-0336	HOUSING, MAIN	1
15.	24-0575	PLATE, RETAINING	1
16.	32-0206	PIN, DOWEL, 1/4" DIA X 5/8"	2
17.	32-0170	PIN, DOWEL, 1/4" DIA X 1 1/2"	1
18.	32-0188	PIN, TRIPPER, 1/8"	2
19.	33-0032	SCREW, CAP, #10-24 X 1"	4
20.	33-0033	SCREW, CAP, #10-24 X 1 1/4"	2
21.	33-0927	SCREW, SET, 1/4-20 X 1/2", HDOG	1
22.	39-0396	GEAR, ASSEMBLY, WORM	1
23.	39-0384	GEAR, PINION	2
24.	39-0386	GEAR, DRIVE	1
25.	43-0263	COVER, HOUSING	1
26.	45-0098	BUSHING, BRONZE	1



## Model 550 Tube Severing Tool

### Parts List, Model 550-20, Tube Cutter (P/N 01-1070)

Item No.	Part No.	Description	Qty
	02-2067	CARRIAGE ASSEMBLY, CUTTER	1
1.	19-0361	HOUSING, CUTTER	1
2.	32-0019	PIN, ROLL, 3/32" DIA X 7/8"	1
3.	32-0114	PIN, DOWEL, 1/4" DIA X 1 1/4"	2
4.			
5.	32-0248	PIN, WHEEL SECURING	1
6.	38-0069	SPROCKET ASSEMBLY, FEED	1
7.	39-0394	GEAR, CARRIAGE	1
8.	40-0141	SPRING, TORSION	1
9.	54-0272	PLUG, SHORT, BEARING	2
10.	54-0273	PLUG, LONG, BEARING	2
11.	61-0009	WHEEL, CUTTER, 3/4"	1
12.	62-0076	CAM ASSEMBLY, FEED	1
13.	63-0088	ARM, CUTTER	1
14.	19-0337	HOUSING, MAIN	1
15.	24-0576	PLATE, RETAINING	1
16.	32-0206	PIN, DOWEL, 1/4" DIA X 5/8"	2
17.	32-0170	PIN, DOWEL, 1/4" DIA X 1 1/2"	1
18.	32-0188	PIN, TRIPPER, 1/8"	2
19.	33-0032	SCREW, CAP, #10-24 X 1"	4
20.	33-0033	SCREW, CAP, #10-24 X 1 1/4"	2
21.	33-0927	SCREW, SET, 1/4-20 X 1/2", HDOG	1
22.	39-0397	GEAR, ASSEMBLY, WORM	1
23.	39-0384	GEAR, PINION	2
24.	39-0393	GEAR, DRIVE	1
25.	43-0264	COVER, HOUSING	1
26.	45-0113	BUSHING, BRONZE	1

**TRI TOOL INC.**

---

## Parts List, Model 550-24, Tube Cutter (P/N 01-1071)

<b>Item No.</b>	<b>Part No.</b>	<b>Description</b>	<b>Qty</b>
	02-2068	CARRIAGE ASSEMBLY, CUTTER	1
1.	19-0360	HOUSING, CUTTER	1
2.	32-0019	PIN, ROLL, 3/32" DIA X 7/8"	1
3.	32-0114	PIN, DOWEL, 1/4" DIA X 1 1/4"	2
4.			
5.	32-0248	PIN, WHEEL SECURING	1
6.	38-0070	SPROCKET ASSEMBLY, FEED	1
7.	39-0395	GEAR, CARRIAGE	1
8.	40-0141	SPRING, TORSION	1
9.	54-0272	PLUG, SHORT, BEARING	2
10.	54-0273	PLUG, LONG, BEARING	2
11.	61-0009	WHEEL, CUTTER, 3/4"	1
12.	62-0077	CAM ASSEMBLY, FEED	1
13.	63-0088	ARM, CUTTER	1
14.	19-0338	HOUSING, FEED	1
15.	24-0577	PLATE, RETAINING	1
16.	32-0175	PIN, DOWEL, 3/8" DIA X 5/8"	2
17.	32-0148	PIN, DOWEL, 3/8" DIA X 1 1/2"	1
18.	32-0188	PIN, TRIPPER, 1/8"	2
19.	33-0032	SCREW, CAP, #10-24 X 1"	4
20.	33-0033	SCREW, CAP, #10-24 X 1 1/4"	2
21.	33-0927	SCREW, SET, 1/4-20 X 1/2", HDOG	1
22.	39-0398	GEAR, ASSEMBLY, WORM	1
23.	39-0391	GEAR, PINION	2
24.	39-0392	GEAR, DRIVE	1
25.	43-0265	COVER, HOUSING	1
26.	45-0113	BUSHING, BRONZE	1

## Model 550 Tube Severing Tool

### Parts List, Model 550-28, Tube Cutter (P/N 01-1072)

Item No.	Part No.	Description	Qty
	02-2069	CARRIAGE ASSEMBLY, CUTTER	1
1.	19-0362	HOUSING, CUTTER	1
2.	32-0019	PIN, ROLL, 3/32" DIA X 7/8"	1
3.	32-0114	PIN, DOWEL, 1/4" DIA X 1 1/4"	2
4.			
5.	32-0248	PIN, WHEEL SECURING	1
6.	38-0070	SPROCKET ASSEMBLY, FEED	1
7.	39-0414	GEAR, CARRIAGE	1
8.	40-0141	SPRING, TORSION	1
9.	54-0272	PLUG, SHORT, BEARING	2
10.	54-0273	PLUG, LONG, BEARING	2
11.	61-0009	WHEEL, CUTTER, 3/4"	1
12.	62-0078	CAM ASSEMBLY, FEED	1
13.	63-0089	ARM, CUTTER	1
14.	19-0339	HOUSING, FEED	1
15.	24-0578	PLATE, RETAINING	1
16.	32-0175	PIN, DOWEL, 3/8" DIA X 5/8"	2
17.	32-0148	PIN, DOWEL, 3/8" DIA X 1 1/2"	1
18.	32-0188	PIN, TRIPPER, 1/8"	2
19.	33-0032	SCREW, CAP, #10-24 X 1"	4
20.	33-0033	SCREW, CAP, #10-24 X 1 1/4"	2
21.	33-0927	SCREW, SET, 1/4-20 X 1/2", HDOG	1
22.	39-0399	GEAR, ASSEMBLY, WORM	1
23.	39-0409	GEAR, PINION	2
24.	39-0412	GEAR, DRIVE	1
25.	43-0266	COVER, HOUSING	1
26.	45-0113	BUSHING, BRONZE	1

MODEL 550-32 TUBE SEVERING TOOL (P/N 01-1073)

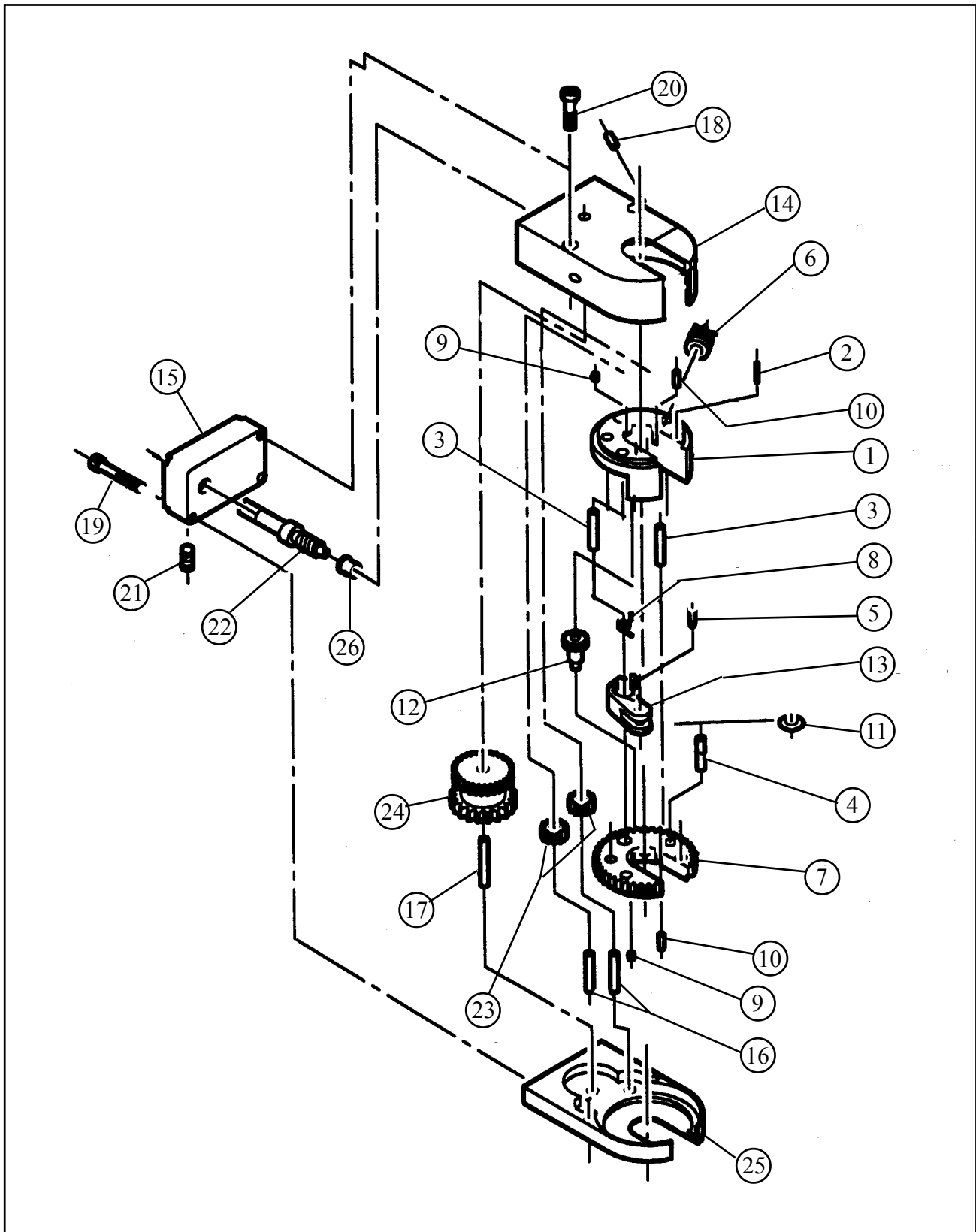

## Model 550 Tube Severing Tool

### Parts List, Model 550-32, Tube Cutter (P/N 01-1073)

Item No.	Part No.	Description	Qty
	02-2070	CARRIAGE ASSEMBLY, CUTTER	1
1.	19-0363	HOUSING, CUTTER	1
2.	32-0019	PIN, ROLL, 3/32" DIA X 7/8"	1
3.	32-0114	PIN, DOWEL, 1/4" DIA X 1 1/4"	2
4.			
5.	32-0248	PIN, WHEEL SECURING	1
6.	38-0070	SPROCKET ASSEMBLY, FEED	1
7.	39-0415	GEAR, CARRIAGE	1
8.	40-0141	SPRING, TORSION	1
9.	54-0272	PLUG, SHORT, BEARING	2
10.	54-0273	PLUG, LONG, BEARING	2
11.	61-0009	WHEEL, CUTTER, 3/4"	1
12.	62-0078	CAM ASSEMBLY, FEED	1
13.	63-0089	ARM, CUTTER	1
14.	19-0340	HOUSING, FEED	1
15.	24-0579	PLATE, RETAINING	1
16.	32-0175	PIN, DOWEL, 3/8" DIA X 5/8"	2
17.	32-0148	PIN, DOWEL, 3/8" DIA X 1 1/2"	1
18.	32-0188	PIN, TRIPPER, 1/8"	2
19.	33-0032	SCREW, CAP, #10-24 X 1"	4
20.	33-0033	SCREW, CAP, #10-24 X 1 1/4"	2
21.	33-0927	SCREW, SET, 1/4-20 X 1/2", HDOG	1
22.	39-0400	GEAR, ASSEMBLY, WORM	1
23.	39-0409	GEAR, PINION	2
24.	39-0413	GEAR, DRIVE	1
25.	43-0267	COVER, HOUSING	1
26.	45-0113	BUSHING, BRONZE	1

TUBE CUTTER DRIVE ASSEMBLY (P/N 04-0084)

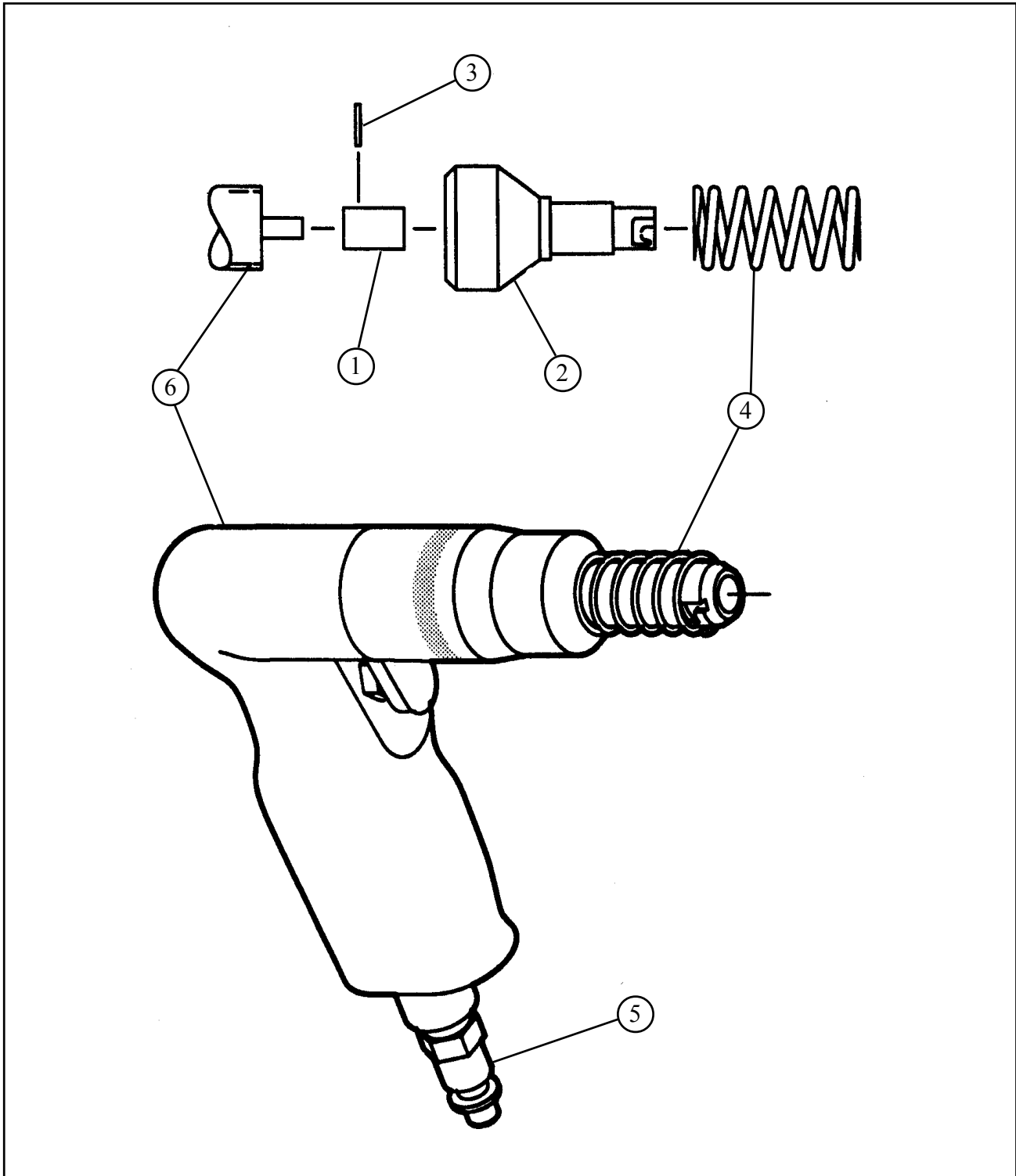

## Model 550 Tube Severing Tool

---

### Parts List, Drive Assembly, Tube Cutter (P/N 04-0084)

<b>Item No.</b>	<b>Part No.</b>	<b>Description</b>	<b>Qty</b>
1.	20-0281	SHAFT, DRIVE	1
2.	22-0073	TUBE, BAYONET MOUNTING	1
3.	32-0024	PIN, ROLL, 1/8" DIA X 1/2"	1
4.	40-0143	SPRING, COMPRESSION	1
5.	54-0127	COUPLING, MALE QD TO 1/4 EPIPE	1
6.	57-0123	MOTOR, AIR. PISTOL, 800RPM	1

**MOTOR ASSEMBLY, CORDLESS, 14.4V (550) (P/N 58-0272)**

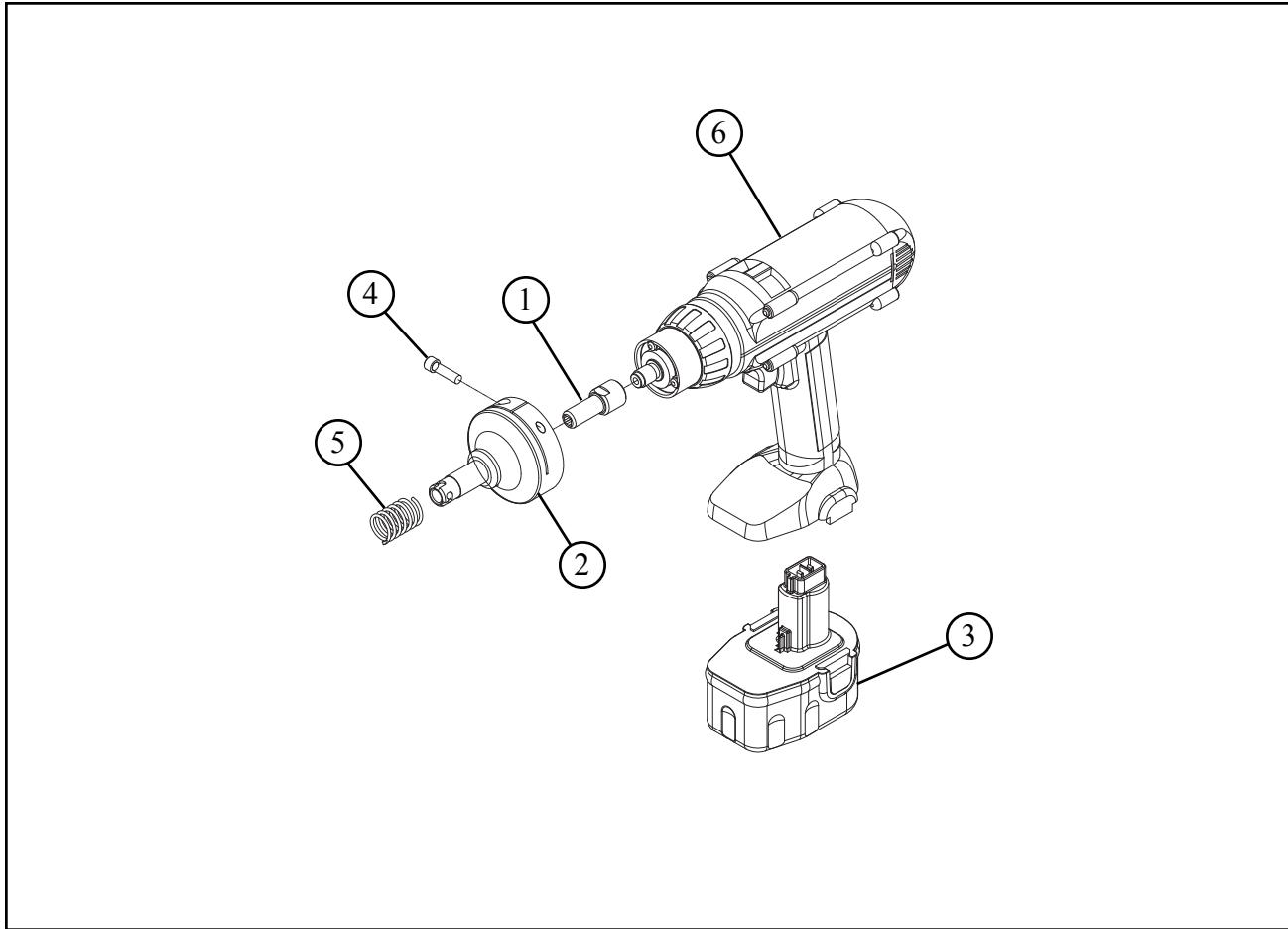

Parts List, Motor Assembly, Cordless, 14.4V (550) (P/N 58-0213)

Item No.	Part No.	Description	Qty
1.	20-1451	SHAFT, DRIVE	1
2.	27-1353	ADAPTER, BAYONET	1
3.	30-2350	BATTERY, 14.4V	1
4.	33-0041	SCREW, CAP, 1/4-20 X 7/8"	1
5.	40-0143	SPRING, COMPRESSION	1
6.	58-0259	MOTOR, CORDLESS, 14.4V	1



## Parts List, A10 Tool Kit (NOT SHOWN)

<b>Item No.</b>	<b>Part No.</b>	<b>Description</b>	<b>Qty</b>
1.	01-1062	MODEL 550-03, TUBE CUTTER	1
2.	01-1063	MODEL 550-04, TUBE CUTTER	1
3.	01-1064	MODEL 550-05, TUBE CUTTER	1
4.	01-1009	MODEL 550-06, TUBE CUTTER	1
5.	01-1065	MODEL 550-08, TUBE CUTTER	1
6.	01-1066	MODEL 550-10, TUBE CUTTER	1
7.	01-1067	MODEL 550-12, TUBE CUTTER	1
8.	01-1068	MODEL 550-16, TUBE CUTTER	1
9.	04-0084	DRIVE ASSY, TUBE CUTTER	1
10.	09-0014	SPARE PARTS KIT	1
11.	14-0036	SHAFT ASSEMBLY, 18" FLEXIBLE	1
12.	36-0128	PLIERS, NEEDLE NOSE	1
13.	36-0130	SCREW DRIVER	1
14.	86-0064	CASE	1

**TRI TOOL INC.**

---

## Parts List, B1 Tool Kit (NOT SHOWN)

<b>Item No.</b>	<b>Part No.</b>	<b>Description</b>	<b>Qty</b>
1.	01-1062	MODEL 550-03, TUBE CUTTER	1
2.	01-1063	MODEL 550-04, TUBE CUTTER	1
3.	01-1064	MODEL 550-05, TUBE CUTTER	1
4.	01-1009	MODEL 550-06, TUBE CUTTER	1
5.	01-1065	MODEL 550-08, TUBE CUTTER	1
6.	01-1066	MODEL 550-10, TUBE CUTTER	1
7.	01-1067	MODEL 550-12, TUBE CUTTER	1
8.	01-1075	MODEL 550-14, TUBE CUTTER	1
9.	01-1068	MODEL 550-16, TUBE CUTTER	1
10.	01-1069	MODEL 550-18, TUBE CUTTER	1
11.	01-1070	MODEL 550-20, TUBE CUTTER	1
12.	01-1071	MODEL 550-24, TUBE CUTTER	1
13.	01-1072	MODEL 550-28, TUBE CUTTER	1
14.	01-1073	MODEL 550-32, TUBE CUTTER	1
15.	04-0084	DRIVE ASSEMBLY, TUBE CUTTER	1
16.	09-0015	SPARE PARTS KIT	1
17.	14-0036	SHAFT ASSEMBLY, 18" FLEXIBLE	1
18.	36-0128	PLIERS, NEEDLE NOSE	1
19.	36-0130	SCREW DRIVER	1
20.	86-0065	CASE	1

**DEWALT SAFETY INSTRUCTIONS**

The DeWALT Cordless Drill/Driver comes with an 'Instruction Manual' and should be referenced for all safety and operating procedures.